

| CURRENT OWNER | | TOPO. | UTILITIES | STRT./ROAD | LOCATION | CURRENT ASSESSMENT | | | |
|--------------------------|--|------------|-----------|------------|----------|--------------------|------|-----------------|----------------|
| SMITH, JOEL & DEBORAH | | 2 High | 5 Well | 1 Paved | | Description | Code | Appraised Value | Assessed Value |
| PO BOX 98 | | 4 Rolling | 6 Septic | | | RESIDENTL | 1010 | 171,800 | 171,800 |
| SANBORNTON, NH 03269 | | | | | | RES LAND | 1010 | 78,200 | 78,200 |
| Additional Owners: | | | | | | RESIDENTL | 1010 | 17,800 | 17,800 |
| SUPPLEMENTAL DATA | | | | | | | | | |
| Other ID: | | 001826 | | | | | | | |
| | | 000000 | | | | | | | |
| ACCT # 1 | | 001395 | | | | | | | |
| ACCT # 2 | | 000000 | | | | | | | |
| GIS ID: | | ASSOC PID# | | | | | | | |
| Total | | | | | | | | 267,800 | 267,800 |

1510
SANBORNTON, NH

VISION

| RECORD OF OWNERSHIP | | BK-VOL/PAGE | SALE DATE | q/u | v/i | SALE PRICE | V.C. | PREVIOUS ASSESSMENTS (HISTORY) | | | | | | | | |
|-----------------------|--|-------------|------------|-----|-----|------------|------|--------------------------------|---------|----------------|------|---------|----------------|------|---------|----------------|
| SMITH, JOEL & DEBORAH | | 1300/0995 | 06/17/1994 | U | V | | 1N | Yr. | Code | Assessed Value | Yr. | Code | Assessed Value | Yr. | Code | Assessed Value |
| | | | | | | | | 2008 | 1010 | 125,600 | 2005 | 1010 | 175,600 | 2004 | 1010 | 106,000 |
| | | | | | | | | 2008 | 1010 | 120,500 | 2005 | 1010 | 76,100 | 2004 | 1010 | 49,300 |
| | | | | | | | | 2008 | 1010 | 25,000 | 2005 | 1010 | 25,000 | 2004 | 1010 | 25,000 |
| Total: | | | | | | | | | 271,100 | Total: | | 276,700 | Total: | | 180,300 | |

| EXEMPTIONS | | | | OTHER ASSESSMENTS | | | |
|---------------|------|-------------|--------|-------------------|-------------|--------|--------|
| Year | Type | Description | Amount | Code | Description | Number | Amount |
| | | | | | | | |
| <i>Total:</i> | | | | | | | |

This signature acknowledges a visit by a Data Collector or Assessor

| ASSESSING NEIGHBORHOOD | | | | |
|------------------------|-----------|-------------------|---------|-------|
| NBHD/ SUB | NBHD Name | Street Index Name | Tracing | Batch |
| A10/A | RES | | | |

APPRAISED VALUE SUMMARY

| | |
|---|----------------|
| Appraised Bldg. Value (Card) | 86,100 |
| Appraised XF (B) Value (Bldg) | 700 |
| Appraised OB (L) Value (Bldg) | 17,800 |
| Appraised Land Value (Bldg) | 78,200 |
| Special Land Value | 0 |
| Total Appraised Parcel Value | 267,800 |
| Valuation Method: | C |
| Exemptions | 0 |
| Adjustment: | 0 |
| Net Total Appraised Parcel Value | 267,800 |

| NOTES | |
|---|-----------------------------|
| GREY IA BRN3 HAS HEAT FBM=1 FAM.ROOM 35% COMPLETE AS OF 4/1/05 SKETCH INCOMPLETE ADDITION IN SECTION 2 07: 100% CMPLT RMV FROM PUL | 12: ADJ DET, DEP, OB, SKTCH |

| BUILDING PERMIT RECORD | | | | | | | |
|------------------------|------------|------|-------------|--------|------------|---------|------------|
| Permit ID | Issue Date | Type | Description | Amount | Insp. Date | % Comp. | Date Comp. |
| 2423 | 04/23/2004 | AD | Addition | 0 | | 100 | 05/30/2007 |

| VISIT/ CHANGE HISTORY | | | | | |
|-----------------------|------|----|----|-----|----------------|
| Date | Type | IS | ID | Cd. | Purpose/Result |
| 02/14/2012 | | | CC | 56 | Field Review |
| 05/30/2007 | | | BP | 00 | Measur Listed |
| 08/05/2006 | | | TO | 00 | Measur Listed |
| 07/30/2005 | | | GH | 00 | Measur Listed |
| 10/28/2003 | | | FA | 00 | Measur Listed |

LAND LINE VALUATION SECTION

| B # | Use Code | Use Description | Zone | D | Front | Depth | Units | Unit Price | I. Factor | S.A. | Acre Disc | C. Factor | ST. Idx | Adj. | Notes- Adj | Special Pricing | S Adj Fact | Adj. Unit Price | Land Value |
|-----|----------|-----------------|------|---|-------|-------|---------|------------|-----------|------|-----------|-----------|---------|------|------------|-----------------|------------|-----------------|------------|
| 1 | 1010 | 1 Family | GA | | 292 | | 1.00 AC | 74,965.00 | 1.0000 | 5 | 1.0000 | 1.00 | A10 | 0.65 | | | 1.00 | 48,727.25 | 48,700 |
| 1 | 1010 | 1 Family | GA | | | | 8.70 AC | 5,500.00 | 1.0000 | 0 | 0.9500 | 1.00 | A10 | 0.65 | | | 1.00 | 3,396.25 | 29,500 |

| CONSTRUCTION DETAIL | | | | CONSTRUCTION DETAIL (CONTINUED) | | | |
|---------------------|-----|-----|----------------|---------------------------------|-----|-----|-------------|
| Element | Cd. | Ch. | Description | Element | Cd. | Ch. | Description |
| Style | 07 | | Modern Contemp | | | | |
| Model | 01 | | Residential | | | | |
| Grade | 04 | | Average +10 | | | | |
| Stories | 1 | | 1 Story | | | | |
| Occupancy | 1 | | | | | | |
| Exterior Wall 1 | 11 | | Clapboard | | | | |
| Exterior Wall 2 | | | | | | | |
| Roof Structure | 03 | | Gable/Hip | | | | |
| Roof Cover | 03 | | Asph/F Gls/Cmp | | | | |
| Interior Wall 1 | 05 | | Drywall/Sheet | | | | |
| Interior Wall 2 | | | | | | | |
| Interior Flr 1 | 09 | | Pine/Soft Wood | | | | |
| Interior Flr 2 | 14 | | Carpet | | | | |
| Heat Fuel | 03 | | Gas | | | | |
| Heat Type | 03 | | Hot Air-no Duc | | | | |
| AC Type | 01 | | None | | | | |
| Total Bedrooms | 02 | | 2 Bedrooms | | | | |
| Total Bthrms | 1 | | | | | | |
| Total Half Baths | 0 | | | | | | |
| Total Xtra Fixtrs | | | | | | | |
| Total Rooms | 5 | | 5 Rooms | | | | |
| Bath Style | 02 | | Average | | | | |
| Kitchen Style | 02 | | Modern | | | | |
| | | | | COST/MARKET VALUATION | | | |
| | | | | Adj. Base Rate: | | | 72.23 |
| | | | | | | | 119,317 |
| | | | | Net Other Adj: | | | 5,500.00 |
| | | | | Replace Cost | | | 124,817 |
| | | | | AYB | | | 1982 |
| | | | | EYB | | | 1982 |
| | | | | Dep Code | | | |
| | | | | Remodel Rating | | | |
| | | | | Year Remodeled | | | |
| | | | | Dep % | | | 31 |
| | | | | Functional Obslnc | | | 0 |
| | | | | External Obslnc | | | 0 |
| | | | | Cost Trend Factor | | | 1 |
| | | | | Condition | | | |
| | | | | % Complete | | | |
| | | | | Overall % Cond | | | 69 |
| | | | | Apprais Val | | | 86,100 |
| | | | | Dep % Ovr | | | 0 |
| | | | | Dep Ovr Comment | | | |
| | | | | Misc Imp Ovr | | | 0 |
| | | | | Misc Imp Ovr Comment | | | |
| | | | | Cost to Cure Ovr | | | 0 |
| | | | | Cost to Cure Ovr Comment | | | |

OB-OUTBUILDING & YARD ITEMS(L) / XF-BUILDING EXTRA FEATURES(B)

| Code | Description | Sub | Sub Descript | L/B | Units | Unit Price | Yr | Gde | Dp Rt | Cnd | %Cnd | Apr Value |
|------|--------------|-----|--------------|-----|-------|------------|------|-----|-------|-----|------|-----------|
| BRN3 | BRN 1 STY LO | | | L | 660 | 22.00 | 2003 | | 0 | | 75 | 10,900 |
| IMP | IMPLEMENT S | | | L | 72 | 9.00 | 2003 | | 0 | | 50 | 300 |
| FCP | CARPOR | | | L | 864 | 11.00 | 2003 | | 0 | | 50 | 4,800 |
| FCP | CARPORT | | | L | 160 | 11.00 | 2010 | | 0 | | 100 | 1,800 |
| HRT | HEARTH | | | B | 1 | 1,000.00 | 1982 | | 1 | | 100 | 700 |

BUILDING SUB-AREA SUMMARY SECTION

| Code | Description | Living Area | Gross Area | Eff. Area | Unit Cost | Undeprec. Value |
|-----------------------------------|--------------------------|--------------|--------------|--------------|-----------|-----------------|
| BAS | First Floor | 1,080 | 1,080 | 1,080 | 72.23 | 78,004 |
| CTH | Cathedral ceil | 0 | 432 | 43 | 7.19 | 3,106 |
| EAF | Attic Expansion Finished | 259 | 648 | 259 | 28.87 | 18,707 |
| FBM | Basement Finished | 0 | 432 | 130 | 21.73 | 9,389 |
| UBM | Basement Unfinished | 0 | 432 | 86 | 14.38 | 6,211 |
| UGR | Garage, Unfinished | 0 | 216 | 54 | 18.06 | 3,900 |
| Ttl. Gross Liv/Lease Area: | | 1,339 | 3,240 | 1,652 | | 124,817 |

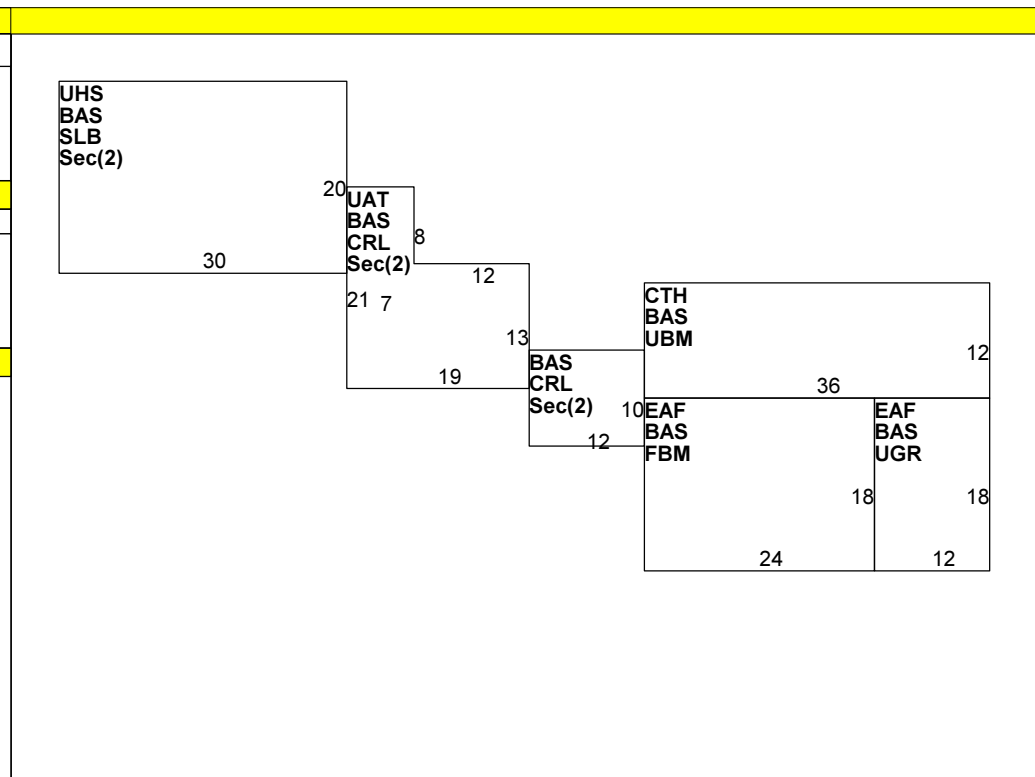

OCT 14 2015

| CURRENT OWNER | | TOPO. | UTILITIES | STRT./ROAD | LOCATION | CURRENT ASSESSMENT | | | |
|--------------------------|--|------------|-----------|------------|----------|--------------------|------|-----------------|----------------|
| SMITH, JOEL & DEBORAH | | 2 High | 5 Well | 1 Paved | | Description | Code | Appraised Value | Assessed Value |
| PO BOX 98 | | 4 Rolling | 6 Septic | | | RESIDENTL | 1010 | 171,800 | 171,800 |
| SANBORNTON, NH 03269 | | | | | | RES LAND | 1010 | 78,200 | 78,200 |
| Additional Owners: | | | | | | RESIDENTL | 1010 | 17,800 | 17,800 |
| SUPPLEMENTAL DATA | | | | | | | | | |
| Other ID: | | 001826 | | | | | | | |
| | | 000000 | | | | | | | |
| ACCT # 1 | | 001395 | | | | | | | |
| ACCT # 2 | | 000000 | | | | | | | |
| GIS ID: | | ASSOC PID# | | | | | | | |
| Total | | | | | | | | 267,800 | 267,800 |

1510
SANBORNTON, NH

VISION

| RECORD OF OWNERSHIP | BK-VOL/PAGE | SALE DATE | q/u | v/i | SALE PRICE | V.C. | PREVIOUS ASSESSMENTS (HISTORY) | | | | | | | | |
|-----------------------|-------------|------------|-----|-----|------------|------|--------------------------------|------|----------------|------|------|----------------|------|------|----------------|
| SMITH, JOEL & DEBORAH | 1300/0995 | 06/17/1994 | U | V | | 1N | Yr. | Code | Assessed Value | Yr. | Code | Assessed Value | Yr. | Code | Assessed Value |
| | | | | | | | 2008 | 1010 | 125,600 | 2005 | 1010 | 175,600 | 2004 | 1010 | 106,000 |
| | | | | | | | 2008 | 1010 | 120,500 | 2005 | 1010 | 76,100 | 2004 | 1010 | 49,300 |
| | | | | | | | 2008 | 1010 | 25,000 | 2005 | 1010 | 25,000 | 2004 | 1010 | 25,000 |
| Total: | | | | | | | | | 271,100 | | | 276,700 | | | 180,300 |

| EXEMPTIONS | | | | OTHER ASSESSMENTS | | | |
|---------------|------|-------------|--------|-------------------|-------------|--------|--------|
| Year | Type | Description | Amount | Code | Description | Number | Amount |
| | | | | | | | |
| Total: | | | | | | | |

This signature acknowledges a visit by a Data Collector or Assessor

| ASSESSING NEIGHBORHOOD | | | | |
|------------------------|-----------|-------------------|---------|-------|
| NBHD/ SUB | NBHD Name | Street Index Name | Tracing | Batch |
| A10/A | RES | | | |

APPRAISED VALUE SUMMARY

| | |
|---|----------------|
| Appraised Bldg. Value (Card) | 85,000 |
| Appraised XF (B) Value (Bldg) | 0 |
| Appraised OB (L) Value (Bldg) | 0 |
| Appraised Land Value (Bldg) | 78,200 |
| Special Land Value | 0 |
| Total Appraised Parcel Value | 267,800 |
| Valuation Method: | C |
| Exemptions | 0 |
| Adjustment: | 0 |
| Net Total Appraised Parcel Value | 267,800 |

| NOTES | |
|---|-----------------------------|
| GREY IA | 12: ADJ DET, DEP, OB, SKTCH |
| BRN3 HAS HEAT | |
| FBM=1 FAM.ROOM | |
| 35% COMPLETE AS OF 4/1/05 | |
| SKETCH INCOMPLETE ADDITION IN SECTION 2 | |
| 07: 100% CMPLT RMV FROM PUL | |

| BUILDING PERMIT RECORD | | | | | | | | VISIT/ CHANGE HISTORY | | | | | | |
|------------------------|------------|------|-------------|--------|------------|---------|------------|-----------------------|------------|------|----|----|-----|----------------|
| Permit ID | Issue Date | Type | Description | Amount | Insp. Date | % Comp. | Date Comp. | Comments | Date | Type | IS | ID | Cd. | Purpose/Result |
| | | | | | | | | | 02/14/2012 | | | CC | 56 | Field Review |
| | | | | | | | | | 05/30/2007 | | | BP | 00 | Measur Listed |
| | | | | | | | | | 08/05/2006 | | | TO | 00 | Measur Listed |
| | | | | | | | | | 07/30/2005 | | | GH | 00 | Measur Listed |
| | | | | | | | | | 10/28/2003 | | | FA | 00 | Measur Listed |

| LAND LINE VALUATION SECTION | | | | | | | | | | | | | | | | | | | |
|-----------------------------|----------|-----------------|------|---|-------|-------|---------|------------|-----------|------|-----------|-----------|---------|------|------------|-----------------|------------|-----------------|------------|
| B # | Use Code | Use Description | Zone | D | Front | Depth | Units | Unit Price | I. Factor | S.A. | Acre Disc | C. Factor | ST. Idx | Adj. | Notes- Adj | Special Pricing | S Adj Fact | Adj. Unit Price | Land Value |
| 1 | 1010 | 1 Family | GA | | 292 | | 1.00 AC | 74,965.00 | 1.0000 | 5 | 1.0000 | 1.00 | A10 | 0.65 | | | 1.00 | 48,727.25 | 48,700 |
| 1 | 1010 | 1 Family | GA | | | | 8.70 AC | 5,500.00 | 1.0000 | 0 | 0.9500 | 1.00 | A10 | 0.65 | | | 1.00 | 3,396.25 | 29,500 |

| CONSTRUCTION DETAIL | | | | CONSTRUCTION DETAIL (CONTINUED) | | | |
|------------------------------|-----|-----|----------------|---------------------------------|-------------|-----|-------------|
| Element | Cd. | Ch. | Description | Element | Cd. | Ch. | Description |
| Style | 07 | | Modern Contemp | | | | |
| Model | 01 | | Residential | | | | |
| Grade | 04 | | Average +10 | | | | |
| Stories | 1 | | 1 Story | | | | |
| Occupancy | 1 | | | | | | |
| MIXED USE | | | | | | | |
| Exterior Wall 1 | 11 | | Clapboard | Code | Description | | Percentage |
| Exterior Wall 2 | | | | 1010 | 1 Family | | 100 |
| Roof Structure | 03 | | Gable/Hip | | | | |
| Roof Cover | 03 | | Asph/F Gls/Cmp | | | | |
| Interior Wall 1 | 05 | | Drywall/Sheet | | | | |
| Interior Wall 2 | | | | | | | |
| COST/MARKET VALUATION | | | | | | | |
| Interior Flr 1 | 09 | | Pine/Soft Wood | Adj. Base Rate: | | | 72.23 |
| Interior Flr 2 | 14 | | Carpet | | | | 86,888 |
| Heat Fuel | 03 | | Gas | Net Other Adj: | | | 5,500.00 |
| Heat Type | 03 | | Hot Air-no Duc | Replace Cost | | | 92,388 |
| AC Type | 01 | | None | AYB | | | 2005 |
| Total Bedrooms | 02 | | 2 Bedrooms | EYB | | | 2005 |
| Total Bthrms | 1 | | | Dep Code | | | A |
| Total Half Baths | 0 | | | Remodel Rating | | | |
| Total Xtra Fixtrs | | | | Year Remodeled | | | |
| Total Rooms | 5 | | 5 Rooms | Dep % | | | 8 |
| Bath Style | 02 | | Average | Functional Obslnc | | | 0 |
| Kitchen Style | 02 | | Modern | External Obslnc | | | 0 |
| | | | | Cost Trend Factor | | | |
| | | | | Condition | | | |
| | | | | % Complete | | | |
| | | | | Overall % Cond | | | 92 |
| | | | | Apprais Val | | | 85,000 |
| | | | | Dep % Ovr | | | 0 |
| | | | | Dep Ovr Comment | | | |
| | | | | Misc Imp Ovr | | | 0 |
| | | | | Misc Imp Ovr Comment | | | |
| | | | | Cost to Cure Ovr | | | 0 |
| | | | | Cost to Cure Ovr Comment | | | |

OB-OUTBUILDING & YARD ITEMS(L) / XF-BUILDING EXTRA FEATURES(B)

| Code | Description | Sub | Sub Descript | L/B | Units | Unit Price | Yr | Gde | Dp Rt | Cnd | %Cnd | Apr Value |
|------|-------------|-----|--------------|-----|-------|------------|----|-----|-------|-----|------|-----------|
| | | | | | | | | | | | | |

BUILDING SUB-AREA SUMMARY SECTION

| Code | Description | Living Area | Gross Area | Eff. Area | Unit Cost | Undeprec. Value |
|------|-----------------------|-------------|------------|-----------|-----------|-----------------|
| BAS | First Floor | 1,023 | 1,023 | 1,023 | 72.23 | 73,887 |
| CRL | Crawl Space | 0 | 423 | 0 | 0.00 | 0 |
| SLB | Slab | 0 | 600 | 0 | 0.00 | 0 |
| UAT | Attic Unfinished | 0 | 303 | 30 | 7.15 | 2,167 |
| UHS | Half Story Unfinished | 0 | 600 | 150 | 18.06 | 10,834 |

| | | | | | | |
|-----------------------------------|--|-------|-------|-------|--|--------|
| Ttl. Gross Liv/Lease Area: | | 1,023 | 2,949 | 1,203 | | 92,388 |
|-----------------------------------|--|-------|-------|-------|--|--------|

